

# Nivz Valves & Automation

## Full Jacketed Sight Glass

Jacketed Double Window Type Sight Flow Indicator, Flanged End

DRG. No.: FJKDW16

00  
Rev. No.

### Nomenclature:-

NO.	PART NAME	MATERIAL
1	Body	A 216 GR. WCB A 351 GR. CF8/CF8M/CF3/CF 3M
2	Cover	M.S. FABRICATED To IS 2062 AISI 304/316/304L/316L
3	Gasket	P.T.F.E./GRAPHITED ASBESTOS
4	Glass	Toughen
5	Fasteners	A 193 GR. B7/2H/S.S. 304/316
6	Jacket	CARBON STEEL/S.S. 304/316
7	Jacket Coupling	CARBON STEEL/S.S. 304/316

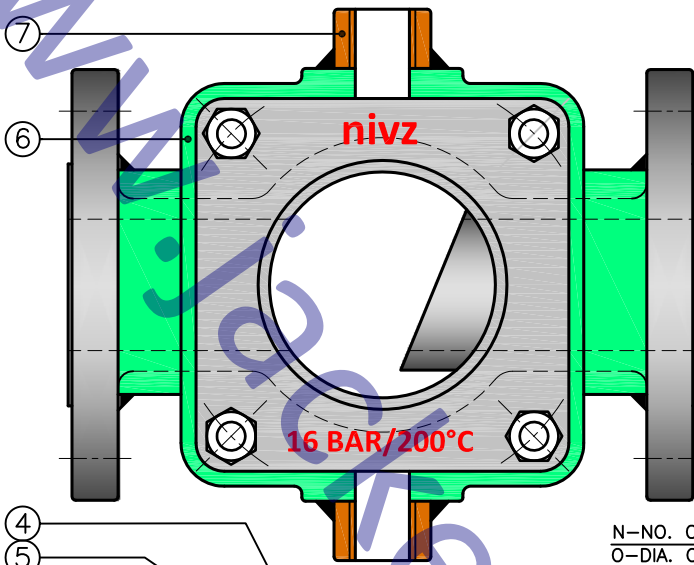

### Jacket Connection

Size 1/2" NPT up to DN50/2"  
Size 3/4" NPT for DN80/3" & DN100/4"  
Size 1" NPT for Above DN100/4"  
Flange Connection on Special Request

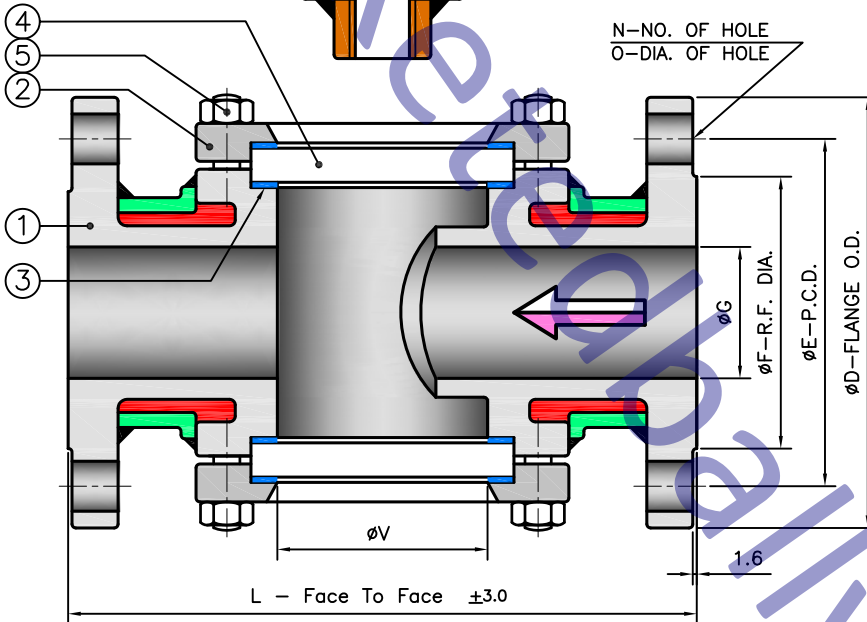

Pressure Rating : PN 10  
End Connection : Flanged End, RF  
Flange Drilling : As Per ANSI B 16.5, Class 150  
Face To Face : DIN EN 558-1

Design Standard : ASME B 16.34

Dimensions [150 Class]

SIZE	25	40	50	65	80	100
L	160	200	230	290	310	350
φG	25	38	50	63	75	100
φV	48	65	75	100	125	150
Drilling Details						
φD	108.0	127.0	152.4	177.8	190.5	228.6
φE	79.2	98.5	120.6	139.7	152.4	190.5
φF	50.8	73.0	92.1	104.7	127.0	157.2
N	4	4	4	4	4	8
φO	15.8	15.8	19	19	19	19

All Dimensions Are In mm

Testing Standard : API 598

Test Pressure in PSIG/BAR/KG./CM<sup>2</sup>

Test	Hydrostatic		
Pr. Rating	PN 16		
Body	228	15.7	16
Jacket	145	9.8	10



VALVES & AUTOMATION

www.nivzvalves.com

Client \_\_\_\_\_

Order / Enq. No. \_\_\_\_\_

Job / Project \_\_\_\_\_

Manufactured By : Nivz Valves & Automation, Ahmedabad, Gujarat, INDIA.

Do Not Copy Drawing

Due to continuous development programme, the design and data given in this leaflet are subject to change without prior notice

© COPYRIGHT

Appd. \_\_\_\_\_  
Chkd. \_\_\_\_\_  
Drwn. \_\_\_\_\_  
 For Record  
 For Reference  
 For Approval